

LN-25 WIRE FEEDER



Portable, Semiautomatic Wire Feeder

LN-25 WIRE FEEDER



The LN-25 shows its portability in demanding applications.

The LN-25 is a semiautomatic constant speed wire feeder for MIG and flux-cored arc welding applications. It is designed for maximum versatility and portability in a variety of field applications.

The LN-25 can be used on most constant voltage, or constant current⁽¹⁾ DC power sources and is designed for “across-the-arc” operation without a control cable. Simply connect the electrode cable, clip the work clamp to the work and it’s ready to weld. Optional voltage output and contactor control are available for improved welding performance. The rugged wire drive assembly features the Lincoln tool-less quick release mechanism for easy changing of the electrode or gun.

ADVANTAGE LINCOLN

- For use with Lincoln flux-cored guns and Magnum® MIG guns.
 - Enhanced starting control allows for smooth arc starting in the CV mode.
 - Dynamic braking system stops wire feed motor quickly to minimize wire overrun.
 - Electronic circuits protect wire feeder from overload.
 - Tool-less quick release wire drive tension system and gun cable connections for easy wire or gun changes.
 - Fully enclosed molded case meets UL94-VO flammability resistance and is heat, spatter, and impact resistant.
 - Case has double latches for easy access to wire and includes an insulated gun holder.
 - Entire unit is compact and portable and will pass through a 16” (406mm) diameter manhole.
 - Optional gas solenoid, timer controls for preflow and postflow gas, internal contactor, and remote voltage control kits available.
 - 3 year warranty on parts and labor.
 - Manufactured under a quality system certified to ISO 9002 requirements.
- ⁽¹⁾Note: Most semiautomatic wire welding processes perform better using constant voltage power sources. Be sure the proper power source is used for your application.

A CLOSER LOOK

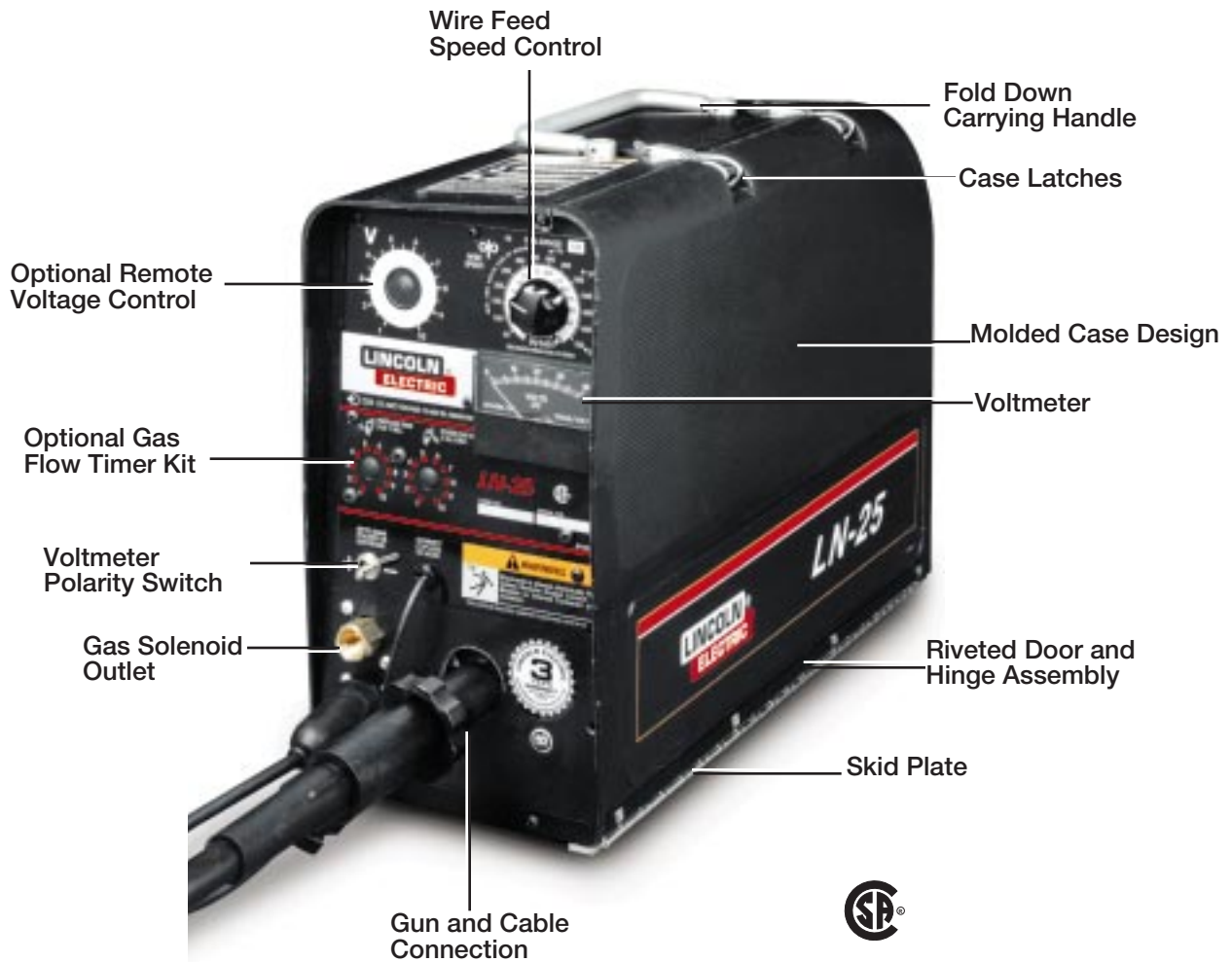

TECHNICAL SPECIFICATIONS

Product Name	Ordering Information	Factory Installed Options	Output Range	Input	Weight (net)	Dimensions HxWxD
LN-25	K449	Internal Contactor and Gas Solenoid	up to 300 Amps 60% duty cycle	Across the arc	33.5 lbs (15.2 kg)	14 x 7.4 x 21 in (356 x 188 x 533mm)
	K428	---	up to 500 Amps 60% duty cycle	(see options)	28 lbs (12.7 kg)	

Across The Arc Set-Up

Electrode cold operation is available with K449 or K428 LN-25's with optional K443-2 Internal Contactor Kit.

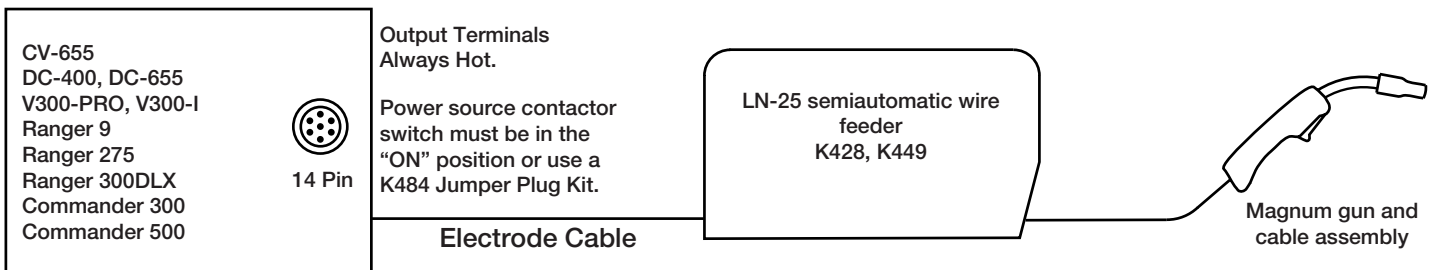
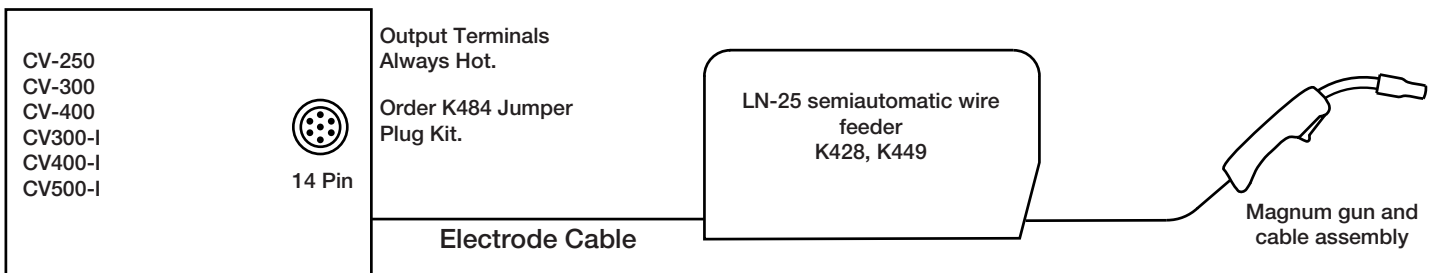
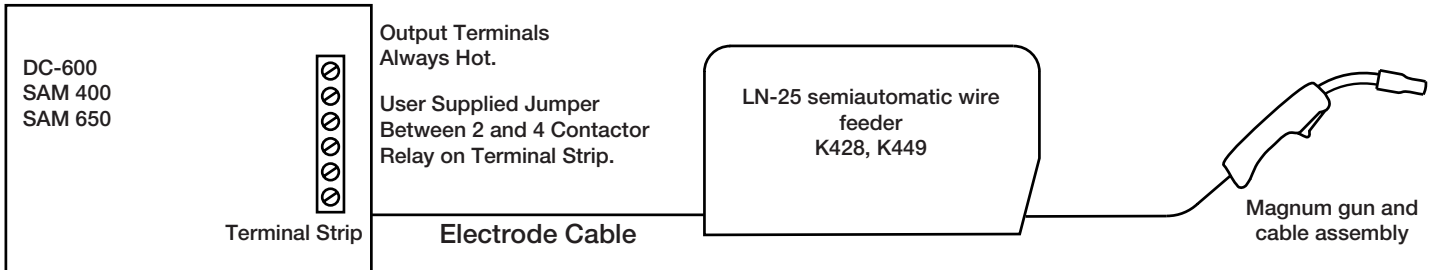
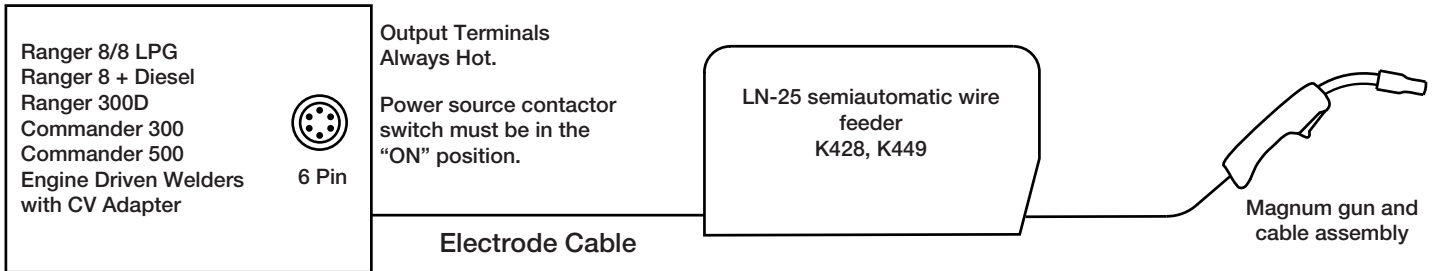
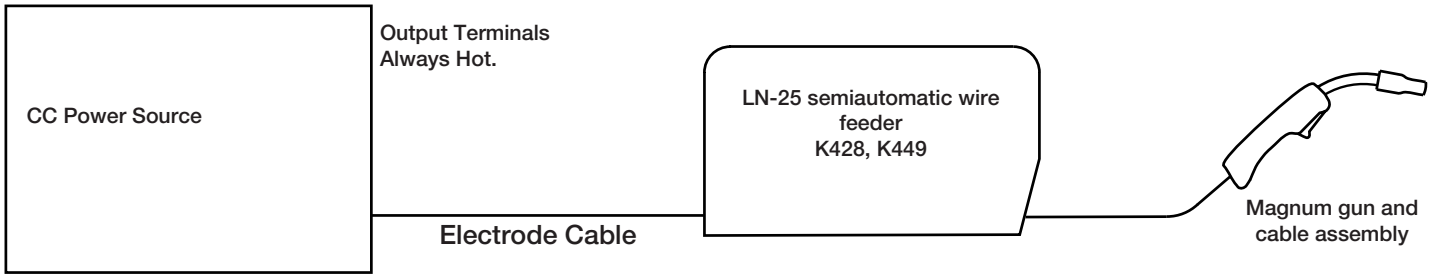

Subject to change without notice.

Across The Arc Set-Up With Remote Voltage Control At LN-25

*Electrode cold operation is available with K449 or K428
LN-25's with optional K443-2 Internal Contactor Kit.*

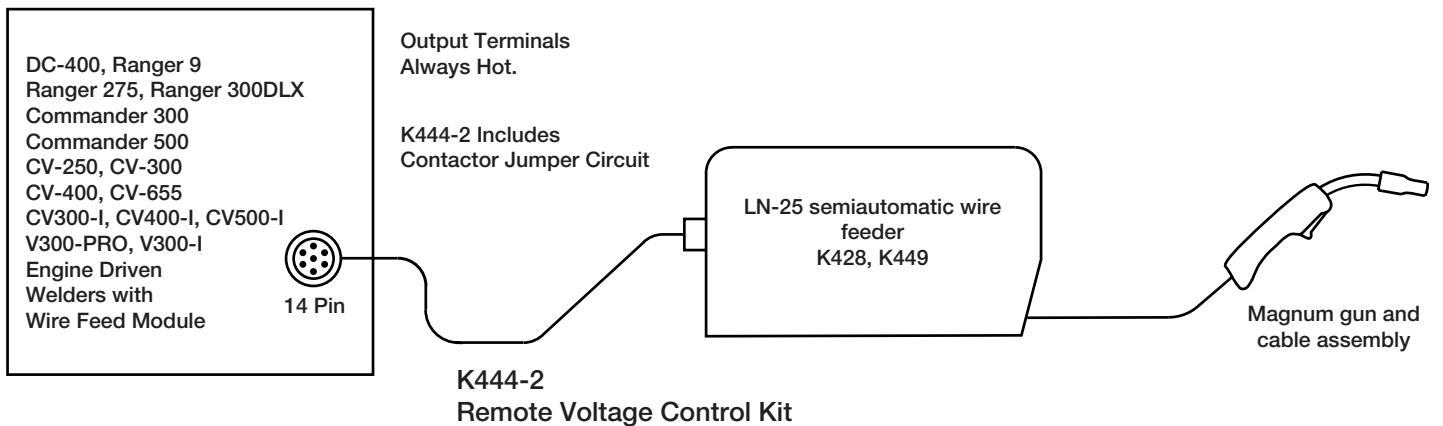
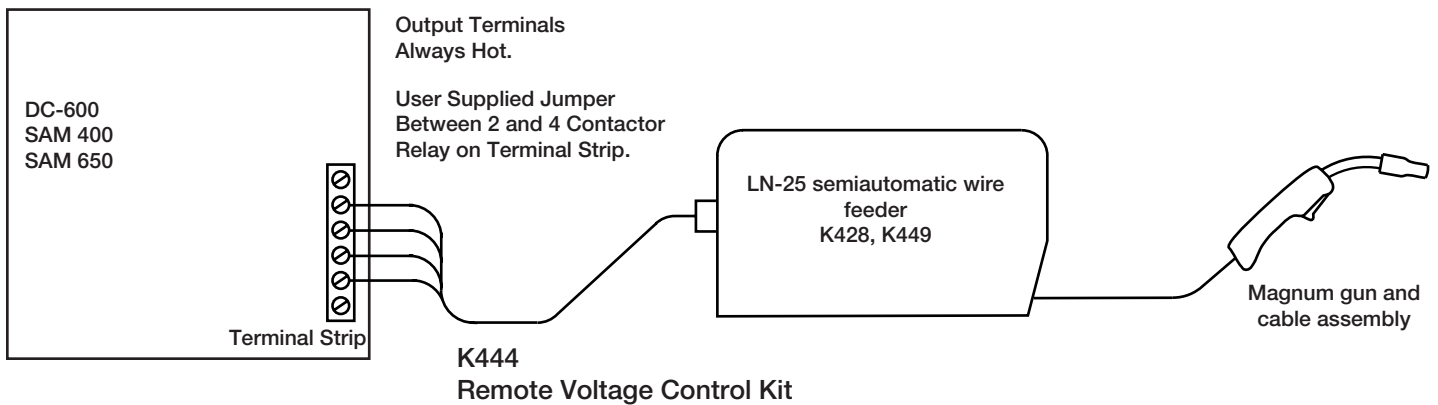
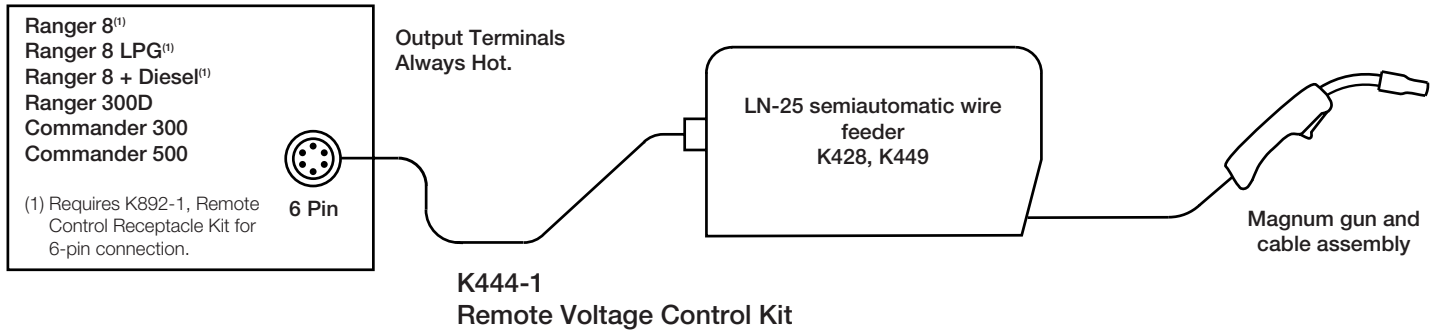

Subject to change without notice.

Across The Arc Set-Up With Electrode Cold Operation And Remote Voltage Control at LN-25

*For LN-25 K428 Model without
Internal Contactor.*

K624-1 42 Volt Remote Output Control Systems

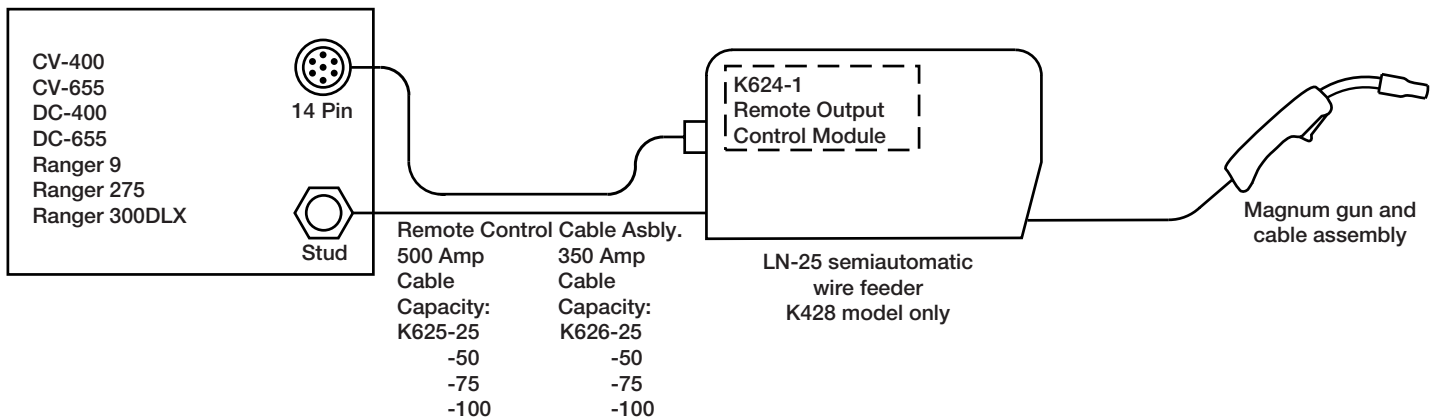
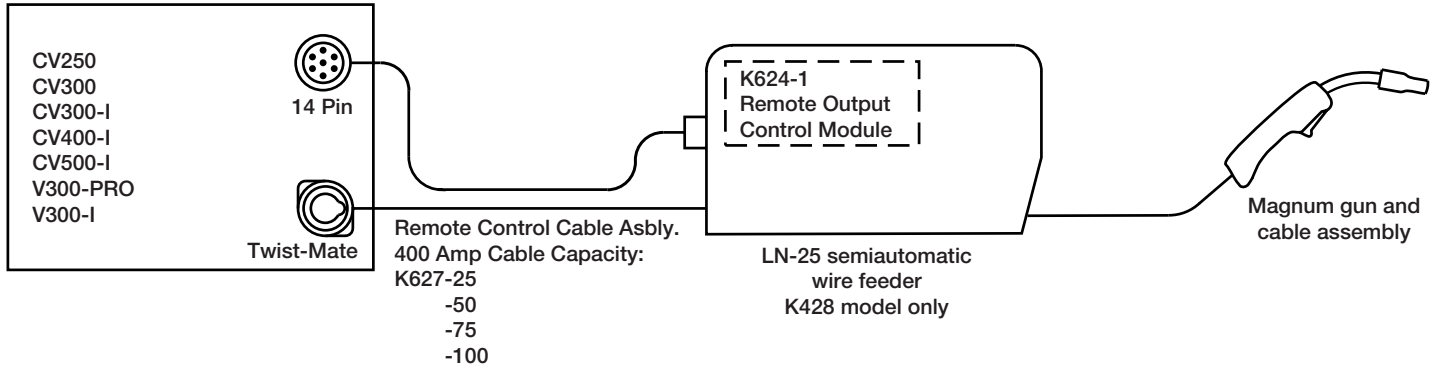

K431-1 and K433 115 Volt Remote Voltage Control Systems

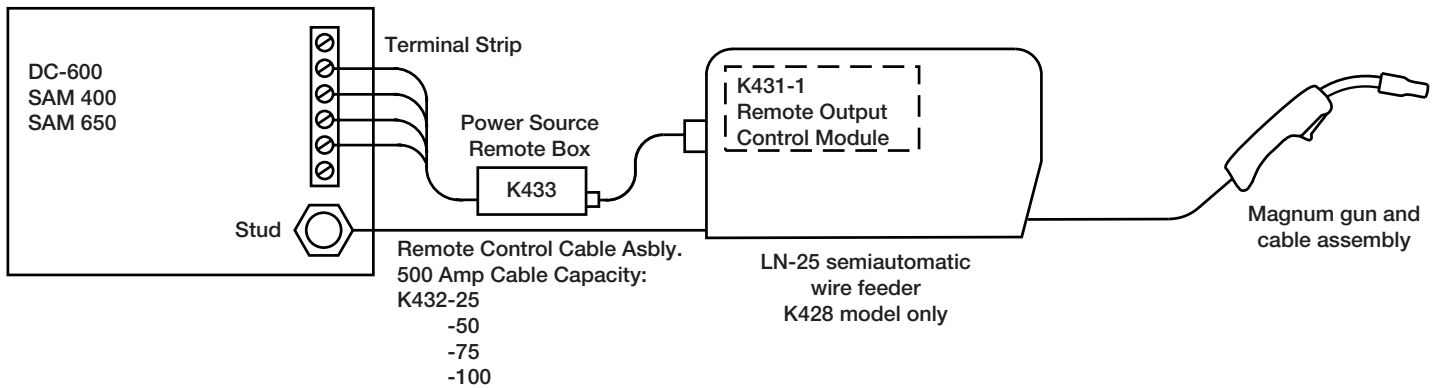

K439 Optional 50 ft. Remote Extension Cable Assembly available. (See Recommended Options).

Subject to change without notice.

RECOMMENDED OPTIONS

REMOTE VOLTAGE CONTROL ONLY KITS

Terminal Strip

Remote Voltage Control Kit

Provides 25 ft. (7.5m) of remote output voltage control with machines having terminal strip. **Order K444.**

6 Pin

Remote Voltage Control Kit

Provides 25 ft. (7.5m) of remote voltage control when used with power sources having 6 pin MS-type (Amphenol) connector. **Order K444-1.**

14 Pin

Remote Voltage Control Kit

Provides 25 ft. (7.5m) of remote output voltage control and output jumper (2 and 4) for machines having 14 pin MS-type (Amphenol) connector. **Order K444-2.**

42 VOLT REMOTE VOLTAGE AND OUTPUT CONTROL

42 Volt Remote Output Control Module

Provides remote voltage control and power source output control. Requires 42 volt auxiliary power. Mounts inside LN-25 control box. Must order either K625, K626 or K627 control cable assembly. **Order K624-1.**

500 Amp Remote Control Cable Assembly

Cable rated 500 amps 60% duty cycle: For power sources with 14 pin MS-Type (Amphenol) connector and stud output terminals. 25, 50, 75, and 100 ft. (7.5, 15.2, 22.8, and 30.4m) lengths. **Order K625-xx.**

350 Amp Remote Control Cable Assembly

Cable rated 350 amps 60% duty cycle: For power sources with 14 pin MS-Type (Amphenol) connector and stud output terminals. 25, 50, 75, and 100 ft. (7.5, 15.2, 22.8, and 30.4m) lengths. **Order K626-xx.**

400 Amp Remote Control Cable Assembly

Cable rated 400 amps 60% duty cycle: For power sources with 14 pin MS-Type (Amphenol) connector and Twist-Mate™ output terminals. 25, 50, 75, and 100 ft. (7.5, 15.2, 22.8, and 30.4m) lengths. **Order K627-xx.**

115 VOLT REMOTE VOLTAGE AND OUTPUT CONTROL

115 Volt Remote Output Control Kit

Provides remote control and power source contactor control. Mounts inside LN-25 control box. Requires K432 cable and 24 volt supply, see K433. **Order K431-1.**

Power Source Remote Box for K431-1

Provides power source control interface and converts 115 volt AC auxiliary to 24 volt supply for LN-25 equipped with K431-1. **Order K433.**

K432 Remote Control Cable Asbly.

Cable rated 500 amps 60% duty cycle: 25, 50, 75, and 100 ft. (7.5, 15.2 22.8, and 30.4m) lengths. 6 pin control connector and stud power connector. For use with K431-1. **Order K432.**

Remote Extension Cable Assembly

For extending K432 remote control cable assembly. 50 ft. (15.0m). **Order K439.**

RECOMMENDED OPTIONS

Gas Solenoid Kit

Includes solenoid valve and mounting bracket. For K428 LN-25 only. (Std. on K449 LN-25 model).

Order K430-2.

Gas Flow Timer Kit

For use with gas solenoid kit. Provides adjustable delays for preflow and postflow of shielding gas.

Order K434-2.

Internal Contactor Kit

Provides cold electrode until gun trigger is pressed and cold inch switch for loading wire. (Std. on K449 LN-25 model).

Order K443-2.

Rear Handle Kit

Provides means to carry LN-25 in the vertical position; especially convenient for passing unit through a manhole. For LN-25 model codes above 9383.

Order K577-1.



Rear Handle Kit

Spindle Adapter for 14 lb. Coils

For 14 lb. (6 kg) Innershield coils. Permits 14 lb. (6 kg) Innershield electrode coils to be mounted on 2" (51mm) O.D. spindles. Wire not included.

Order K435.



Spindle Adapter for 14 lb. Coils.

Spindle Adapter for 8" O.D. Spools

For small spools. Permits 8" (203mm) O.D. spools to be mounted on 2" (51mm) O.D. spindles.

Order K468.



Spindle Adapter for 8" O.D. Spools.

Jumper Plug Kit

For use with CV only power sources with 14 pin MS-type wire feeder connections and no contactor control switch. Jumper plug kit closes contactor for always hot welding output.

Order K484.

Magnum Gun and Cable Assemblies

Available 200-550 amps, air-cooled, gas-shielded welding guns. See bulletin E12.10.



Magnum 400 shown.

Magnum Flux-Cored Gun and Cable Assemblies

Available 250-600 amps. See bulletin E12.10.



Flux-Cored Gun and Cable Assembly shown.

DRIVE ROLL AND GUIDE TUBE KITS

	2 roll
Steel Wire Sizes: .023-.025 (0.6mm) solid .030 (0.8mm) solid .035 (0.9mm) solid .035 (0.9mm) cored .045-.052 (1.2-1.3mm) solid .045-.052 (1.2-1.3mm) cored .052-1/16" (1.3-1/6mm) solid or cored .068-3/32" (1.7-2.4mm) cored	KP653-025S KP653-030S KP653-035S KP653-035C KP653-052S KP653-052C KP653-1/16 KP653-3/32
Aluminum Wire Sizes: .035 (0.9mm) 3/64" (1.2mm) 1/16" (1.6mm)	KP654-035A KP654-3/64A KP654-1/16A

SYSTEM SELECTION

1. Determine the Kit No. to be used in the left hand vertical column.
2. Scan horizontally to determine which LN-25 model is required and what additional kits may be required.

Key: NA Cannot be used with this option or feeder.
 R Required.
 (1) Requires any one of these.
 S Included standard with feeder.
 OPT May be used with these feeders.

Kit No. and Description	LN-25 Models		LN-25 Kits										
	K428 LN-25	K449 LN-25	K431-1	K432	K433	K443-2	K444	K444-1	K444-2	K624-1	K625	K626	K627
K430-2 Gas Solenoid Kit	OPT	S											
K434-1 Gas Flow Timer Kit		OPT	(1)			(1)				(1)			
K439 Remote Ext. Cable Asbly.				R									
K443-2 Internal Contactor Kit	OPT	S	NA							NA			
K444 Remote Voltage Control Kit - Terminal Strip	OPT	OPT	NA							NA			
K444-1 Remote Voltage Control Kit - 6 Pin	OPT	OPT	NA							NA			
K444-2 Remote Voltage Control Kit - 14 Pin	OPT	OPT	NA							NA			
K624-1 42 Volt Remote Output Control Module	OPT	NA	NA			NA	NA	NA	NA		(1)	(1)	(1)
K625-xx 500 Amp Remote Control Cable Assembly Stud-Type - 14 Pin										R			
K626-xx 350 Amp Remote Control Cable Assembly Stud-Type - 14 Pin										R			
K627-xx 400 Amp Remote Control Cable Assembly Twist-Mate™ - 14 Pin										R			
K431-1 Remote Output Control Module	OPT	NA		R	R	NA	NA	NA	NA	NA			
K432 Remote Control Cable Stud-Type - Terminal Strip			R		R								
K433 115 Volt Power Source Remote Box			R	R									

THE TOTAL SOLUTION

Choose from a complete line of Lincoln products to generate the total solution for your welding application:

- Invertec® V300-PRO.
- Idealarc® DC-400, 600, 655.
- Ranger 8, 8 LPG, 8 + Diesel, 9, 275, 300D and 300DLX engine driven welders.
- CV-250, 300, 400, and 655, and CV300-I, 400-I and 500-I.
- SAE 400 and 400 weld 'n air engine driven welders with CV adapter.
- SAM-400 and 650 engine driven welders.
- Classic I, II, III 300D and SA 250 engine driven welders with wire feed module.
- Commander 300.
- Commander 500.



Invertec V300-PRO



DC-400



Ranger 9



Commander 300



SAM-650



Classic 300D with Wire Feed Module

Construction or field welding with Innershield® (self-shielded flux-cored) Wire.



MIG (GMAW) Welding with Solid Wire.

Welding with Outershield® (gas-shielded flux-cored and metal-cored) Wires.



Welding with Lincore® Hardfacing Wire.



LINCOLN NORTH AMERICA

DISTRICT OFFICE AND SALES AGENT LOCATIONS

USA

ALABAMA

BIRMINGHAM 35124-1156
(205) 988-8232
MOBILE 36693-4310
(334) 666-6524

ALASKA

Contact SEATTLE
District Office
(206) 575-2456

ARIZONA

PHOENIX 85260-1768
(602) 348-2004

ARKANSAS

LITTLE ROCK 72116-7034
(501) 771-4842

CALIFORNIA

FRESNO 93722-3949
(209) 276-0110
LOS ANGELES 90670-2936
(562) 906-7700
SACRAMENTO 95677-4729
(916) 630-1885
SAN DIEGO 92108-3911
(619) 208-9001
SAN FRANCISCO 94550-9657
(925) 443-9353

COLORADO

DENVER 80112-5115
(303) 792-2418

CONNECTICUT

NORTH HAVEN 06238
(860) 742-8887

WASHINGTON DC

HERNDON, VA 20170-5227
(703) 904-7735

FLORIDA

JACKSONVILLE 32259-4396
(904) 287-9595
MIAMI 33014-6719
(305) 556-0142
TAMPA 33619-4480
(770) 475-0955

GEORGIA

ATLANTA 30076-4914
(770) 475-0955
SAVANNAH 31401-5140
(912) 231-9604

HAWAII

See SEATTLE
District Office
(206) 575-2456

ILLINOIS

CHICAGO 60521-5629
(630) 920-1500
PEORIA 61607-2046
(309) 697-8240

INDIANA

EVANSVILLE 47710-4514
(812) 428-3225
FT. WAYNE 46825-5547
(219) 484-4422
SOUTH BEND 46530-0577
(219) 277-8619
INDIANAPOLIS 46038-9459
(317) 845-8445

IOWA

CEDAR RAPIDS 52402-3160
(319) 362-6804
MOLINE, ILL 52806-1344
(319) 386-6522
DES MOINES 50265-6218
(515) 224-4121

KANSAS

KANSAS CITY 66214-1625
(913) 894-0888
WICHITA 67037
(316) 788-7352

KENTUCKY

LOUISVILLE 40203-2906
(502) 636-5125

LOUISIANA

BATON ROUGE 70809-2256
(504) 922-5151
SHREVEPORT 71108-2521
(318) 869-3531

MARYLAND

BALTIMORE 21045-2565
(410) 720-5232

MASSACHUSETTS

BOSTON 02154-8414
(781) 899-2010

MICHIGAN

DETROIT 48034-4005
(248) 353-9680
FLUSHING 48433-1855
(810) 487-1310
GRAND RAPIDS 49512-3924
(616) 942-8780

MINNESOTA

MINNEAPOLIS 55447-5435
(612) 551-1990

MISSISSIPPI

JACKSON 39212-9635
(601) 372-7679

MISSOURI

KANSAS CITY (KS) 66214-1625
(913) 894-0888
ST. LOUIS 63146-3572
(314) 993-5465

MONTANA

Contact SEATTLE
District Office
(206) 575-2456

NEBRASKA

OMAHA 68046-2826
(402) 339-1809

NEW JERSEY

EDISON 08837-3939
(732) 225-2000
LEBANON 08833-0700
(888) 427-2269

NEW MEXICO

ALBUQUERQUE 87111-2158
(505) 237-2433

NEW YORK

ALBANY 12205-5427
(518) 482-3389
BUFFALO 14225-5515
(716) 681-5554
NEW YORK CITY
(888) 269-6755
EAST SYRACUSE 13057-1040
(315) 432-0281

NORTH CAROLINA

CHARLOTTE 28273-6200
(704) 588-3251
RALEIGH 27604-8456
(919) 231-5855

OHIO

CINCINNATI 45242-3706
(513) 554-4440
CLEVELAND 44143-1433
(216) 289-4160
COLUMBUS 43221-4073
(614) 488-7913
DAYTON 45439-1254
(937) 299-9506
TOLEDO 43528-9483
(419) 867-7284

OKLAHOMA

OKLAHOMA CITY 73119-2416
(405) 686-1170
TULSA 74146-1622
(918) 622-9353

OREGON

PORTLAND 97230-1030
(503) 252-8835

PENNSYLVANIA

BETHLEHEM 18020-2062
(610) 866-8788
ERIE 16506-2979
(814) 835-3531
JOHNSTOWN 15905-2506
(814) 535-5895
PHILADELPHIA 19008-4310
(610) 543-9462
PITTSBURGH 15275-1002
(412) 787-7733
YORK 17404-1144
(717) 764-6565

SOUTH CAROLINA

FLORENCE 29505-3615
(803) 673-0830
GREENVILLE 29612-0126
(864) 967-4157

SOUTH DAKOTA

SIOUX FALLS 57108-2609
(605) 339-6522

TENNESSEE

KNOXVILLE 37923-4506
(423) 693-5513
MEMPHIS 38115-5946
(901) 363-1075
NASHVILLE 37210-3816
(615) 316-9777
TRI-CITIES 37604-3338
(423) 928-6047

TEXAS

CONROE 77304-1524
(409) 588-1116
DALLAS 76051-7602
(817) 329-9353
HOUSTON 77060-3143
(281) 847-9444
SAN ANTONIO 78133-3502
(830) 964-2421

UTAH

MIDVALE 84047-3759
(801) 233-9353

VIRGINIA

HERNDON 20170-5227
Washington, D.C.
(703) 904-7735
ROANOKE 24153-1447
(540) 389-4032
WILLIAMSBURG 23602-7048
(757) 881-9762

WASHINGTON

SEATTLE 98188-7615
(206) 575-2456
SPOKANE 99005-9637
(509) 468-2770

WEST VIRGINIA

CHARLESTON 25526-9796
(304) 757-9862

WISCONSIN

GREEN BAY 54302-1829
(920) 435-1012
MILWAUKEE 53186-0403
(414) 650-9364

CANADA

ALBERTA

CALGARY T2H 2M3
(403) 253-9600
EDMONTON T6H 2K1
(403) 436-7385
WINNIPEG R3N 0C7
(204) 488-6398

BRITISH COLUMBIA

VANCOUVER V3H 3W8
(604) 306-0339

MARITIMES

NOVA SCOTIA B2X 3N2
(902) 434-2725

MANITOBA

WINNIPEG R3N 0C7
(204) 488-6398

ONTARIO

TORONTO M4G 2B9
(416) 421-2600

QUEBEC

MONTREAL J5Y 2G3
(514) 654-3121

LINCOLN INTERNATIONAL HEADQUARTERS

22801 St. Clair Avenue, Cleveland, Ohio 44117-1199 USA

Phone: (216) 481-8100 • Fax: (216) 486-1363 • Website: www.lincolnelectric.com

Contact International Headquarters in Cleveland, Ohio
for Specific Locations of over 120
International Distributors Worldwide



DISTRIBUTED BY:

**THE
LINCOLN ELECTRIC
COMPANY**

Local Sales and Service through Global
Subsidiaries and Distributors

Cleveland, Ohio 44117-1199 U.S.A.

TEL (216) 481-8100

FAX (216) 486-1751

WEB SITE www.lincolnelectric.com

**Semiautomatic Wire Feeders
E8.100 2/99**